

TECHNICAL SPECIFICATION

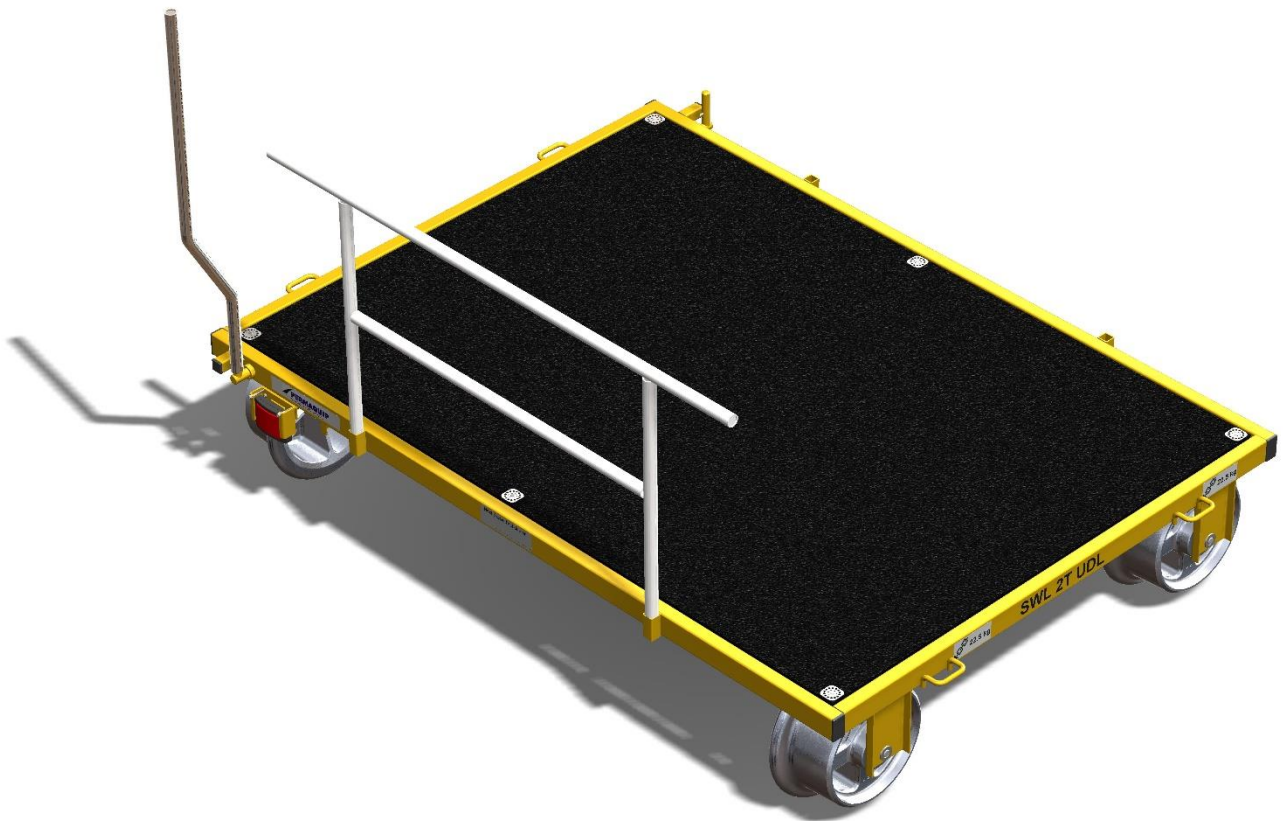

TYPE A TROLLEY



Permaquip Ltd

Old Sleningford Farm,
North Stainley,
Ripon,
North Yorkshire, HG4 3JB

Tel: +44 (0) 1623 513349

E-mail: sales@permaquip.co.uk
www.permaquip.co.uk



MADE IN BRITAIN

Description:

The Permaquip™ Type A Trolley is designed to be used as a manual propelled, stand-alone load-bearing rolling platform for use on-track.

Each Type A Trolley is equipped with a fail-safe braking system and is supplied with detachable brake and push handles.

The design is available with multiple additional options including standard or electrically insulated wheels, aluminium or wooden deck, swing lift crane & gas bottle carrier.

The Type A Trolley can be safely stacked in multiples of five during transit provided that this is within the vehicles operating capabilities and the load is secure and stable. They can be stacked in multiples of eight for storage.

Type A trolley chassis' are powder coated yellow for high visibility when on track and supplied with red flashing LED lights to aid awareness when in low light conditions.

Type A Trolley Layout:

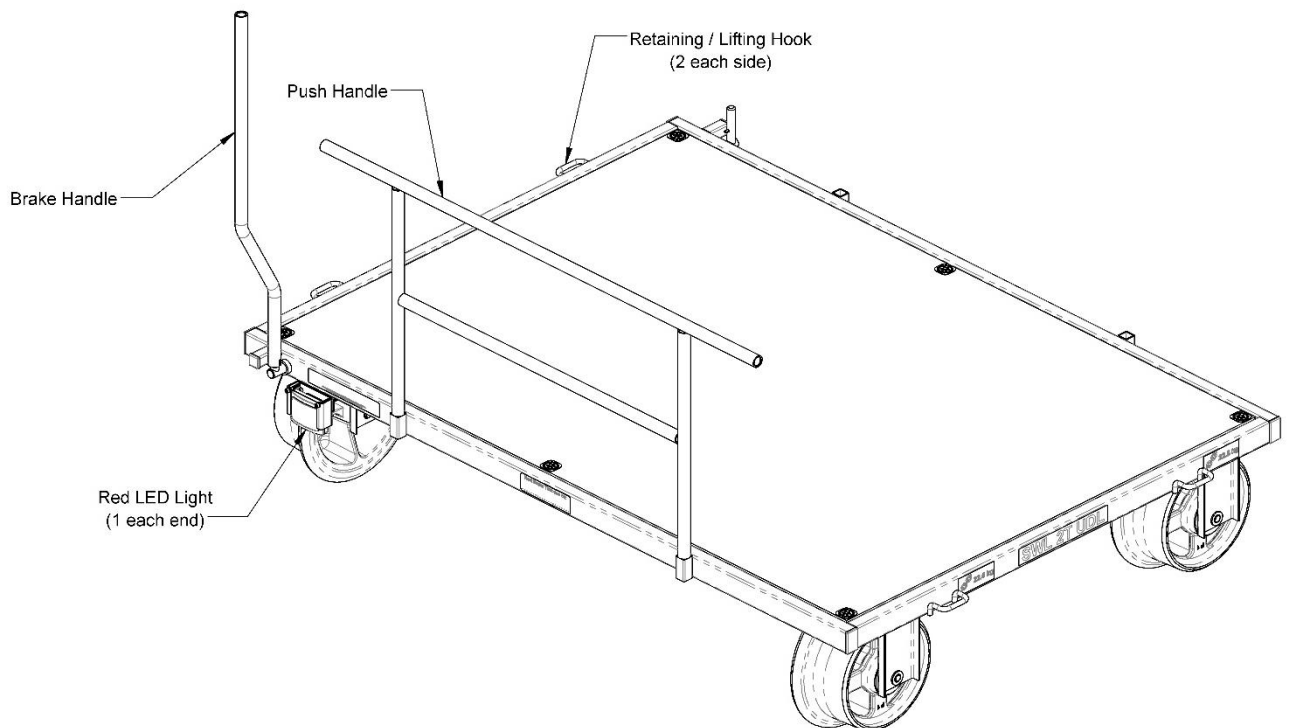

Technical Data:

Type A Trolley Part Numbers:

- Type A Trolley Non-Insulated Wheels Wooden Deck 23716
- Type A Trolley Insulated Wheels Wooden Deck 27786
- Type A Trolley Non-Insulated Wheels Aluminium Deck 27787
- Type A Trolley Insulated Wheels Aluminium Deck 27788

Overall dimensions:

- Length 1330mm
- Width 1795mm
- Height to push handle from top of rail head 850mm

Platform dimensions:

- Length 1220mm
- Width 1695mm
- Height from top of rail head 304mm

Track Gauge: 1435mm (Various other gauges available upon request)

SWL: 2000kg UDL (1000kg on NWR & LUL Infrastructure)

Mass: 100kg

Wheels:

- Material: Aluminium
- Profile: P1
- Rolling Diameter 10"
- Insulation (Optional) 5 MΩ

Brakes: Failsafe braking as standard tested in line with CoP 0018

Maximum Cant: 150mm

Maximum Gradient: 1 in 30

Product Compliance:

- RIS-1701PLT
- BS EN13977

Please note:

All information, illustrations and specifications in this Technical Sheet are based on the latest information available at the time of publication. The right is reserved to make changes at any time without notice.

Equipment operators and installers shall be responsible for ensuring that a safe working environment and safe systems of work are in place and in certain circumstances advice and permission from the controlling authority must be sought before any operation, installation or surveying work is carried out.

Permaquip™ is a trademark of Permaquip Ltd.

©2006 Permaquip Ltd.

Permaquip Type A Trolley

